

# BERT FRANK

## REVOLVE TABLE LAMP

### MAINTENANCE

- Lacquered brass and diffuser should be wiped with a soft duster.
- Coloured parts can be wiped with a damp cloth (unplug from mains first).

### TECHNICAL

- 3 x G9 LED bulbs

www.bertfrank.co.uk  
+44 (0)207 164 6482

### BULB REPLACEMENT

- 1**
- Unplug the lamp from the mains.
  - Unscrew the top finial.

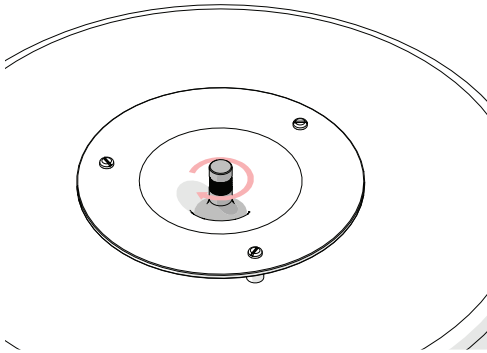

- 2**
- Remove the top finial and shade.

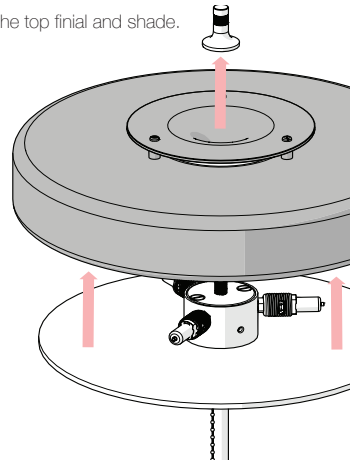

- 3**
- Replace bulbs by pushing them into lamp holder.

!! If lamp has been in use recently ensure you leave enough time for the old bulbs to cool down before removing them. !!

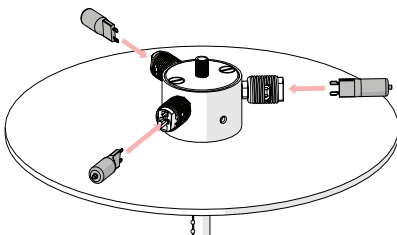

- 4**
- Once bulbs are installed replace shade and top finial.

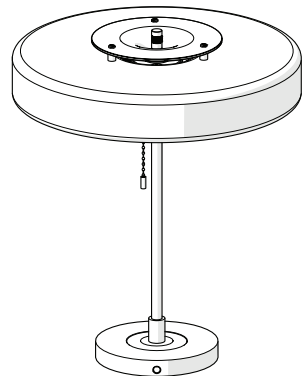

---

This product is only suitable for connection to the native power supply to which the unit was specifically manufactured. It is for indoor use only, and not suitable for a bathroom location.

If the Class II, double insulated symbol is on the lamp, it does not require an Earth, and Live or Neutral must not be connected to Earth. If there is no such symbol, then the lamp must be Earthed.

Under no circumstances must this table lamp be covered with any material as this could pose a safety hazard. It must be used on a stable, flat surface.

Never fit bulbs of a higher wattage than those specified on the label, as these may cause overheating and damage the fitting.

If the mains cable becomes damaged it must only be replaced by a technically competent, qualified person.

Allow 10 minutes to cool before replacing, adjusting or cleaning. Clean with a dry cloth only. Do not use liquid or abrasive cleaners on this product.

If you are in any doubt about your competence please consult a qualified electrician. If any modification is made it will invalidate the warranty and may render the product unsafe.

---